



STUDY MATERIAL

VIVEKANANDA COLLEGE THAKURPUKUR

NAAC ACCREDITED GRADE—'A'

Subject: Molecular Biology

Topic: Replication

Name of the Teacher: Dr. Dibyendu Raj

Central dogma

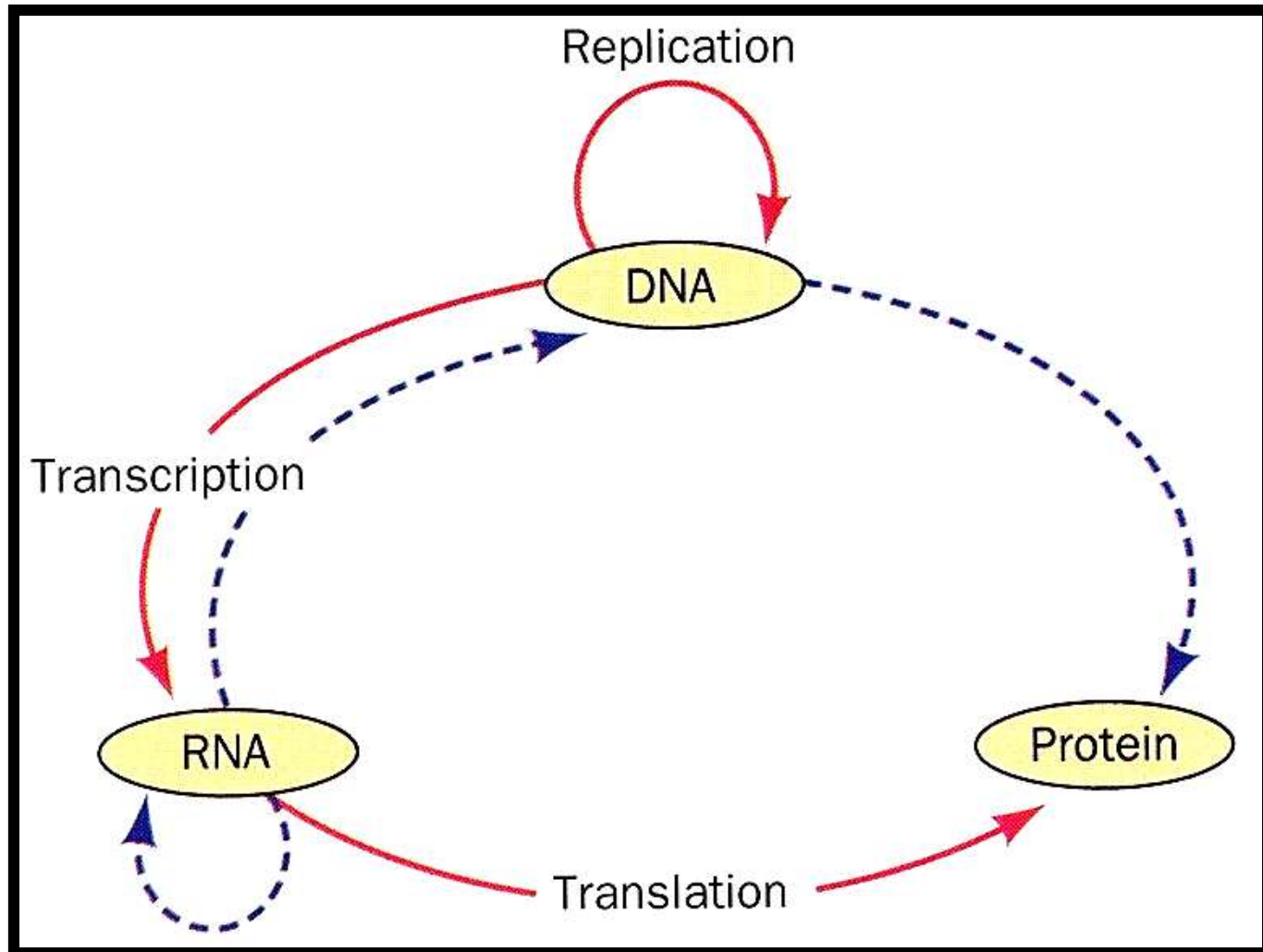

DNA replication: 3 possible models

Copyright © The McGraw-Hill Companies, Inc. Permission required for reproduction or display.

(a) Semiconservative (b) Conservative (c) Dispersive

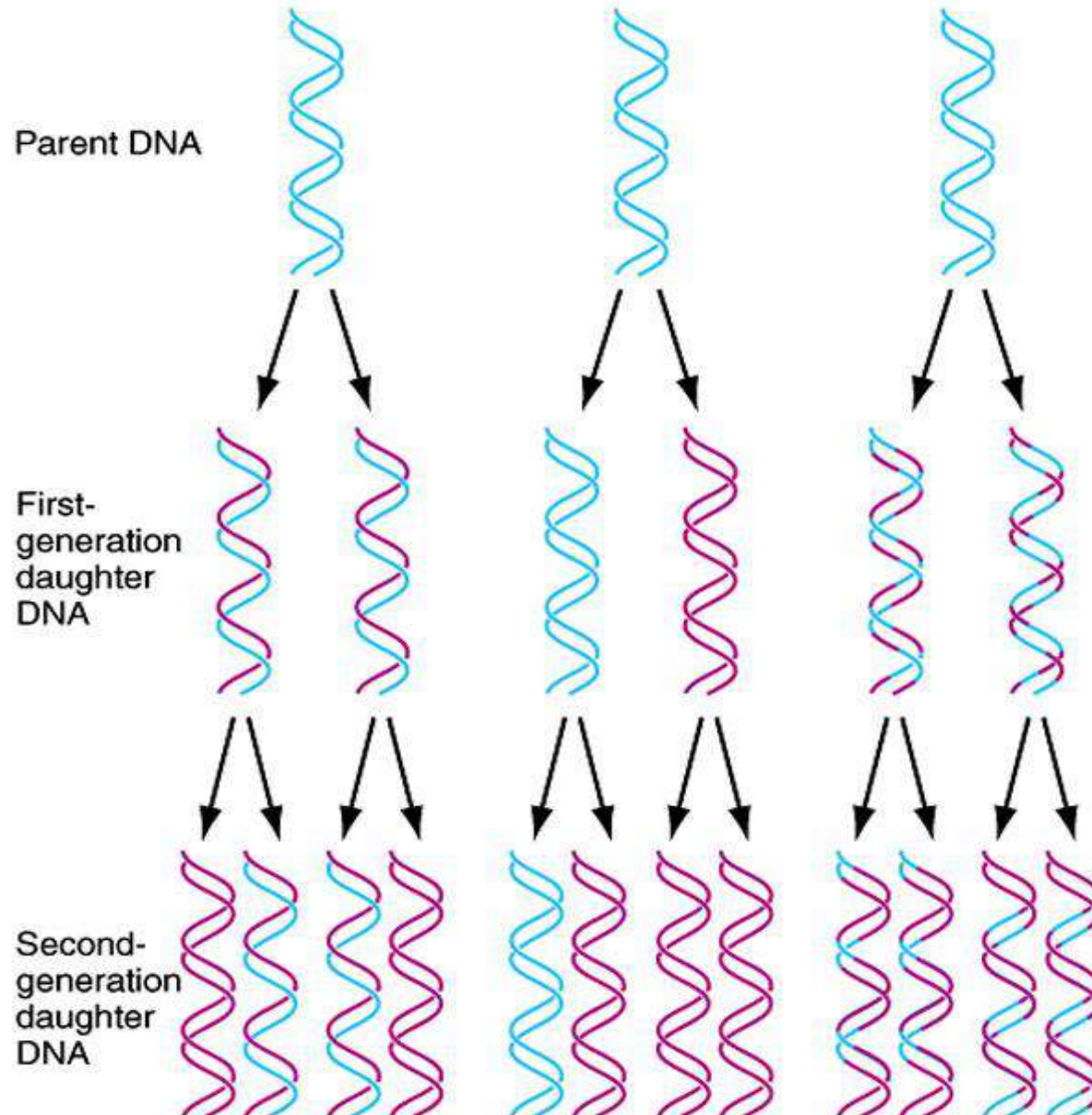

How do we know that DNA replication is semi-conservative?

Meselson-Stahl experiments

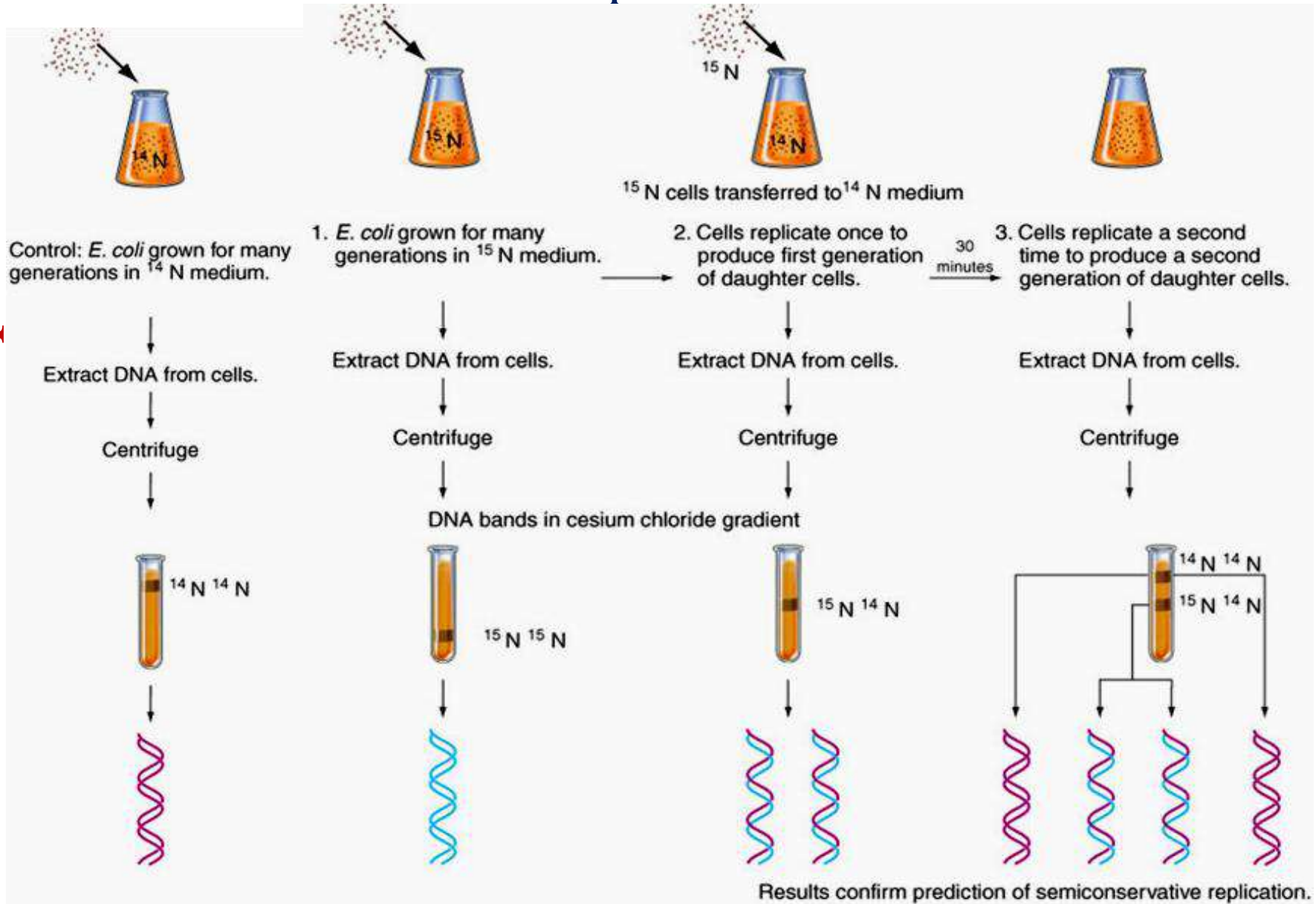

Core proteins involved at the replication fork during Replication

- Topoisomerases** - Prevents torsion by DNA breaks
- Helicases** - separates 2 strands
- Primase** - RNA primer synthesis
- Single strand binding proteins** - prevent re-annealing of single strands
- DNA polymerase** - synthesis of new strand
- Tethering protein** - stabilises polymerase
- DNA ligase** - seals nick via phosphodiester linkage

Replication mechanism

- **Strand Separation:**

1. **Helicase:** enzyme which catalyze the **unwinding** and **separation** (breaking H-Bonds) of the parental double helix.

2. **Single-Strand Binding Proteins:** proteins which attach and help keep the separated strands apart.

3. **Topoisomerase:** enzyme which **relieves stress** on the **DNA molecule** by allowing free rotation around a single strand.

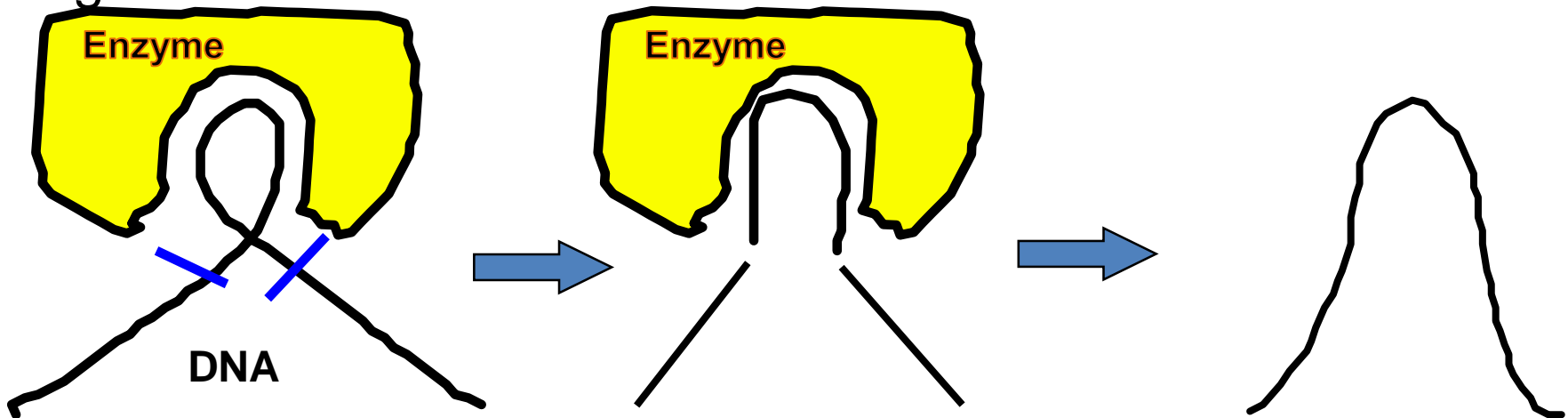

Supercoiled DNA relaxed by gyrase & unwound by helicase

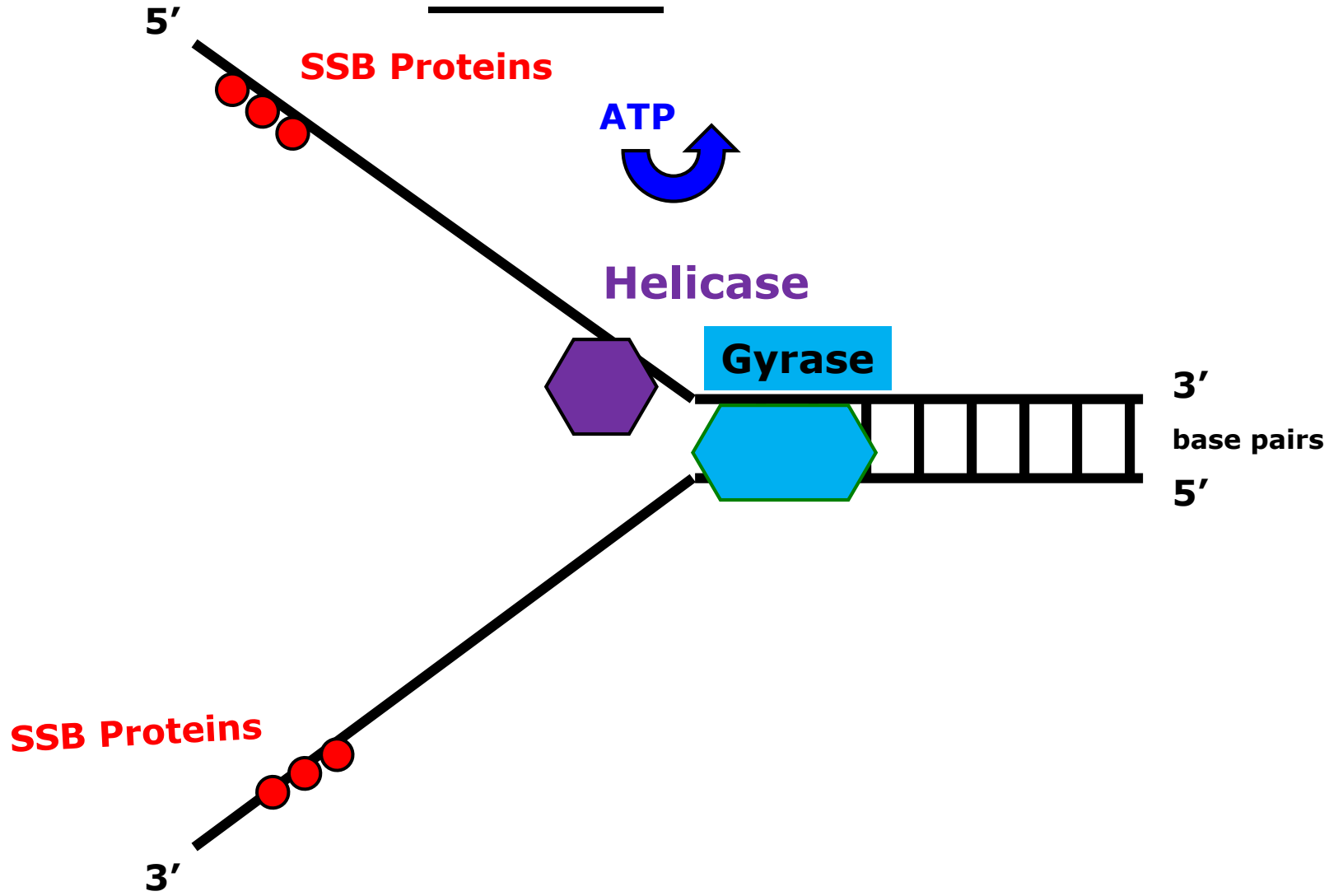

Supercoiled DNA relaxed by gyrase & unwound by helicase + proteins:

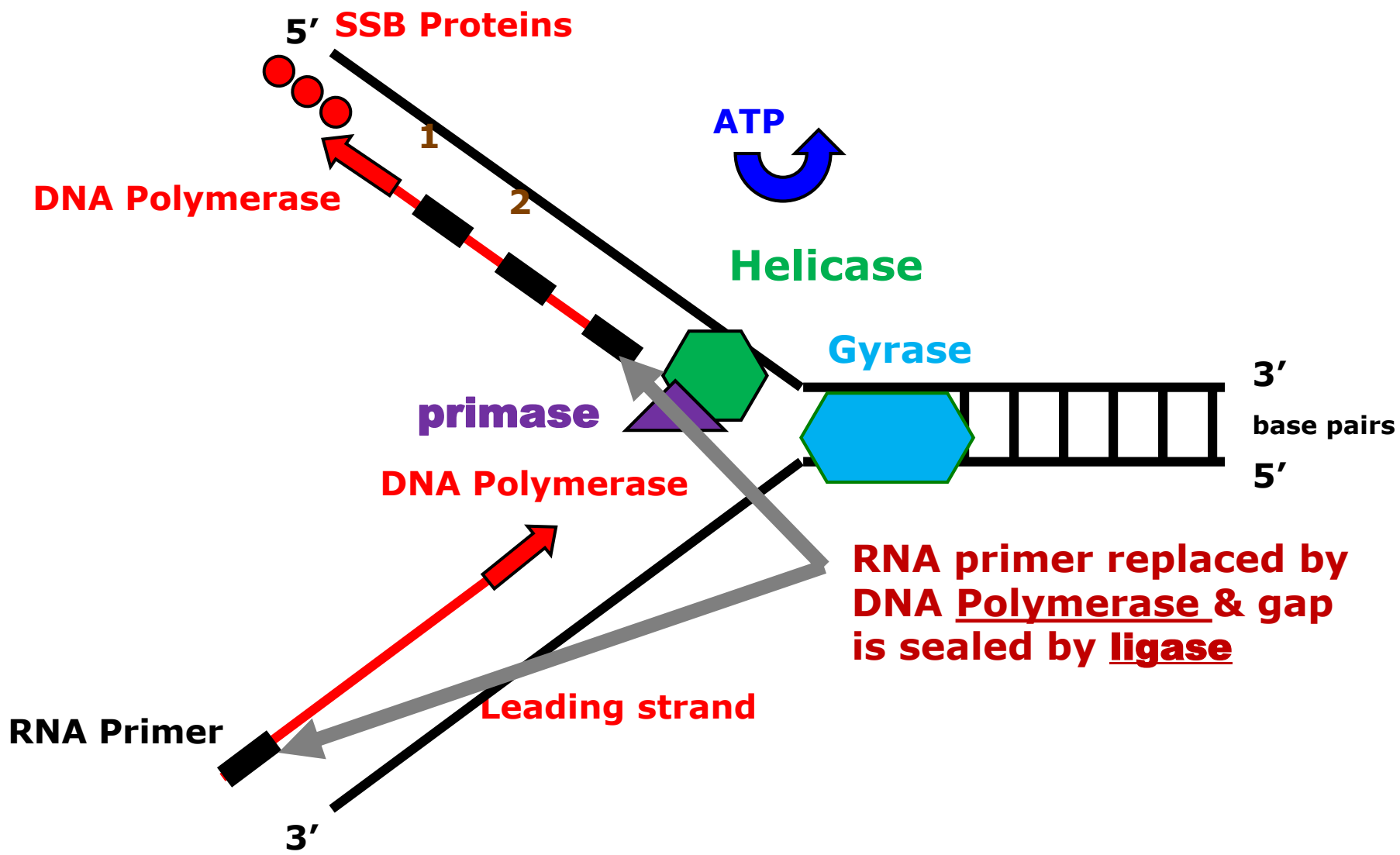

- **Priming:**

1. **RNA primers:** Before new DNA strands can form, there must be small pre-existing **primers (RNA)** present to start the addition of new nucleotides (**DNA Polymerase**).

2. **Primase:** enzyme that polymerizes (synthesizes) the **RNA Primer**.

- **Synthesis of the new DNA Strands:**

1. **DNA Polymerase:** with a **RNA primer** in place, **DNA Polymerase** (enzyme) catalyze the **synthesis of a new DNA strand in the 5'to 3' direction**.

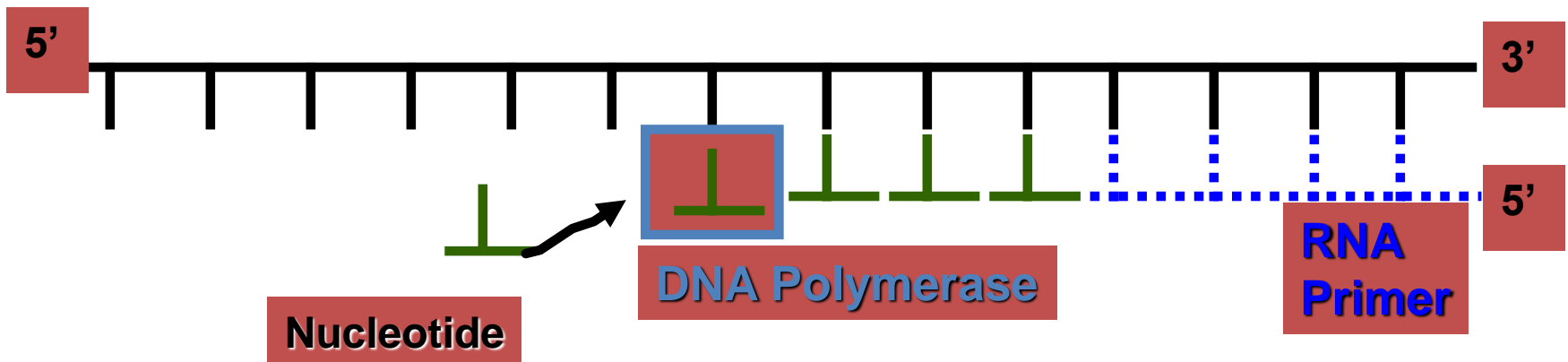

2. **Leading Strand:** synthesized as a **single polymer** in the **5' to 3' direction.**

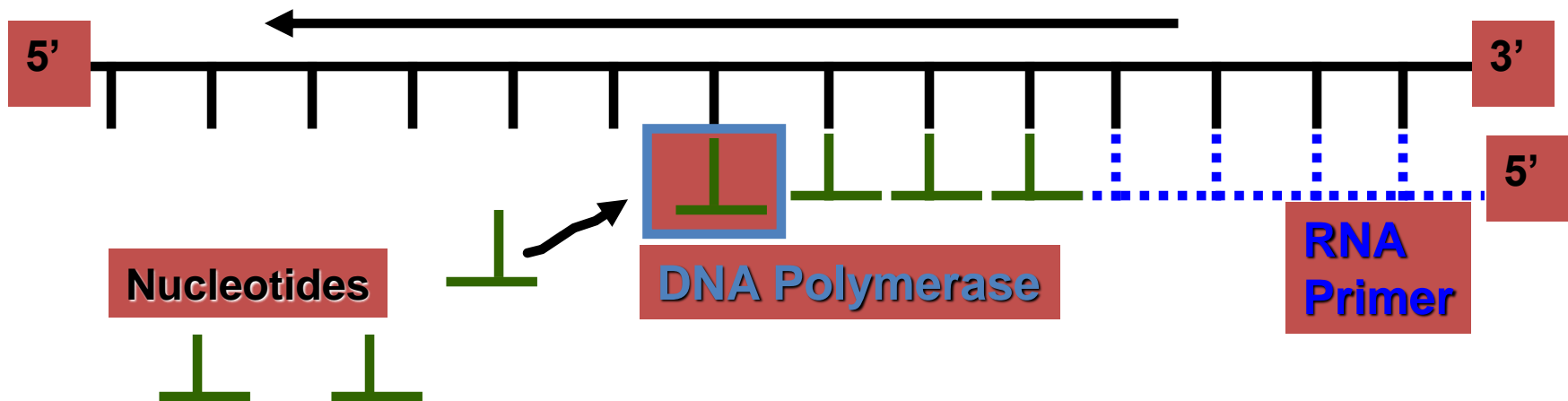

DNA Replication

3. Lagging Strand: also synthesized in the **5' to 3'** direction, but **discontinuously** against overall direction of replication.

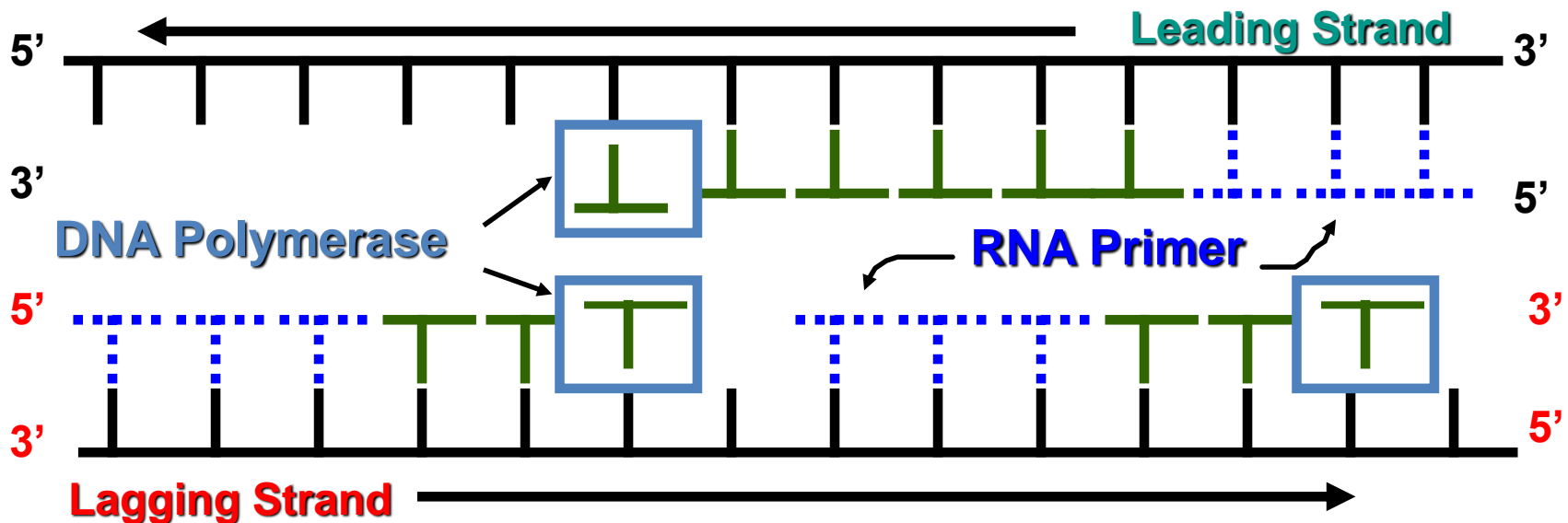

4. Elongation:

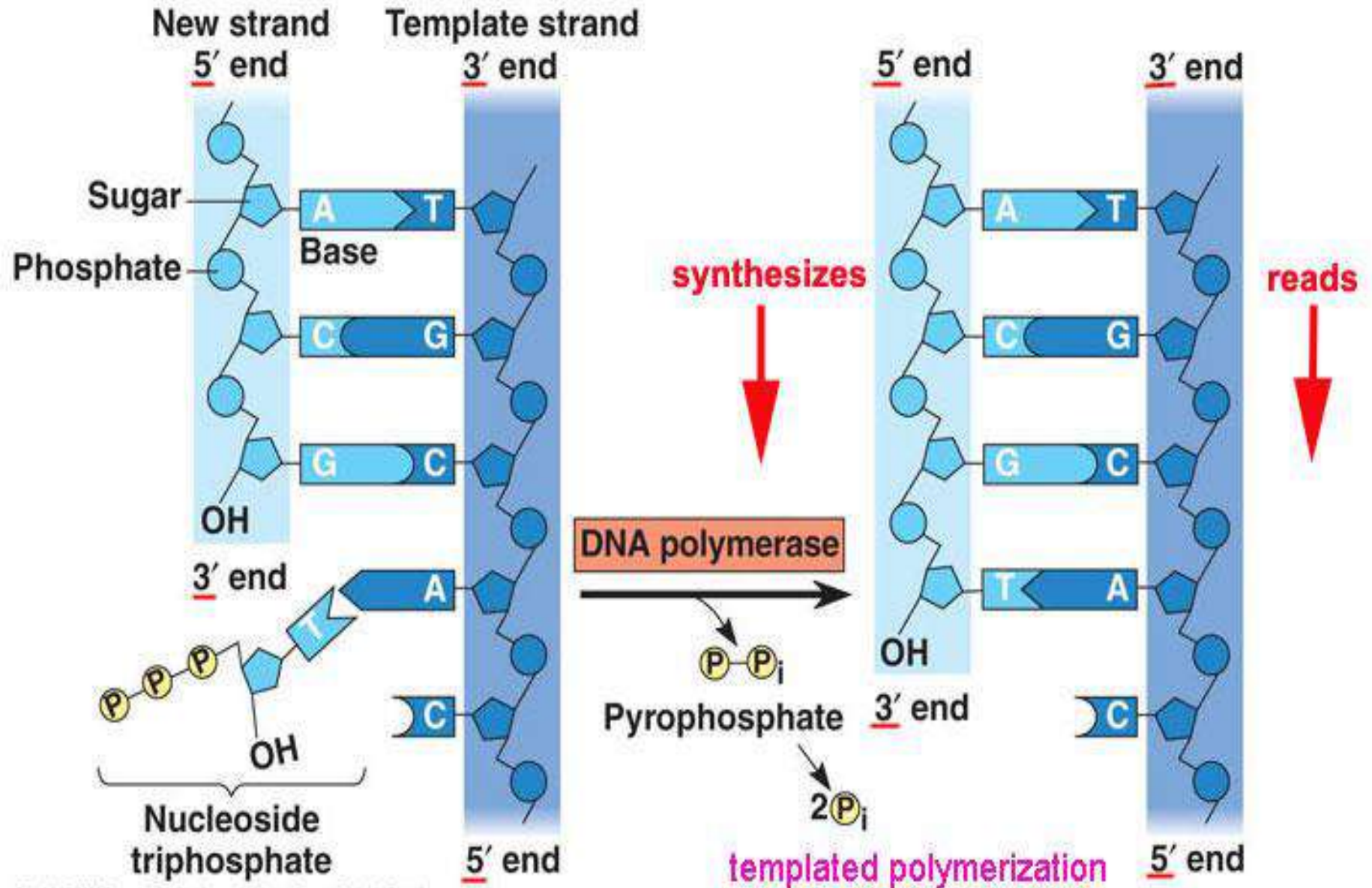

DNA Replication

5. **DNA ligase**: a linking enzyme that catalyzes the formation of a covalent bond from the **3' to 5' end** of joining stands.

Example: joining two Okazaki fragments together.

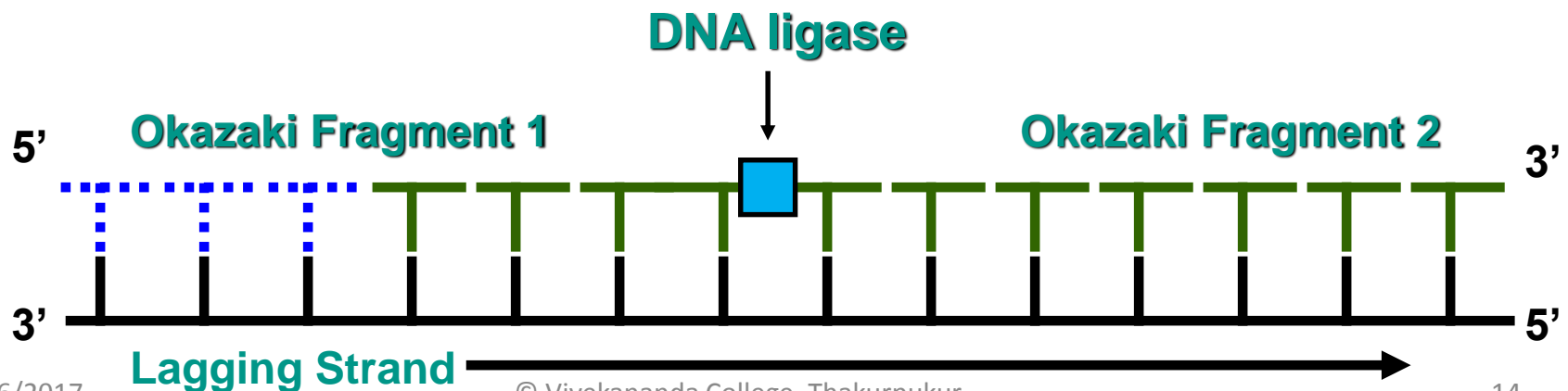

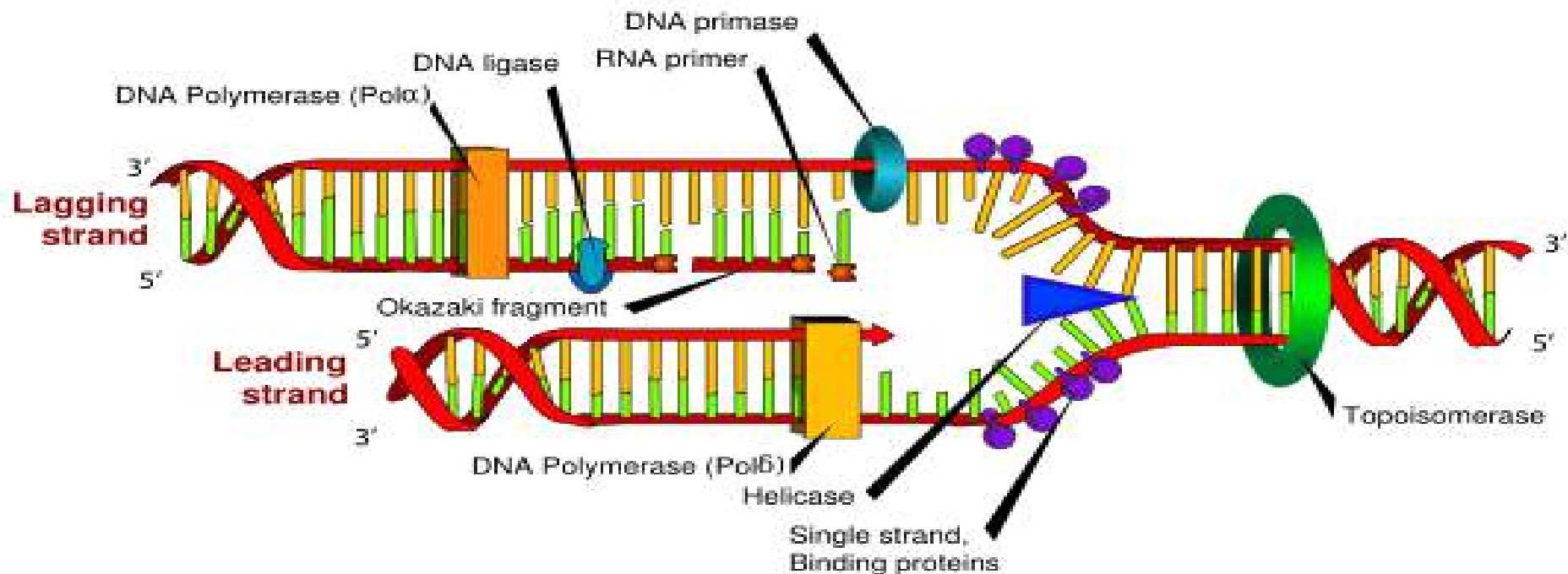
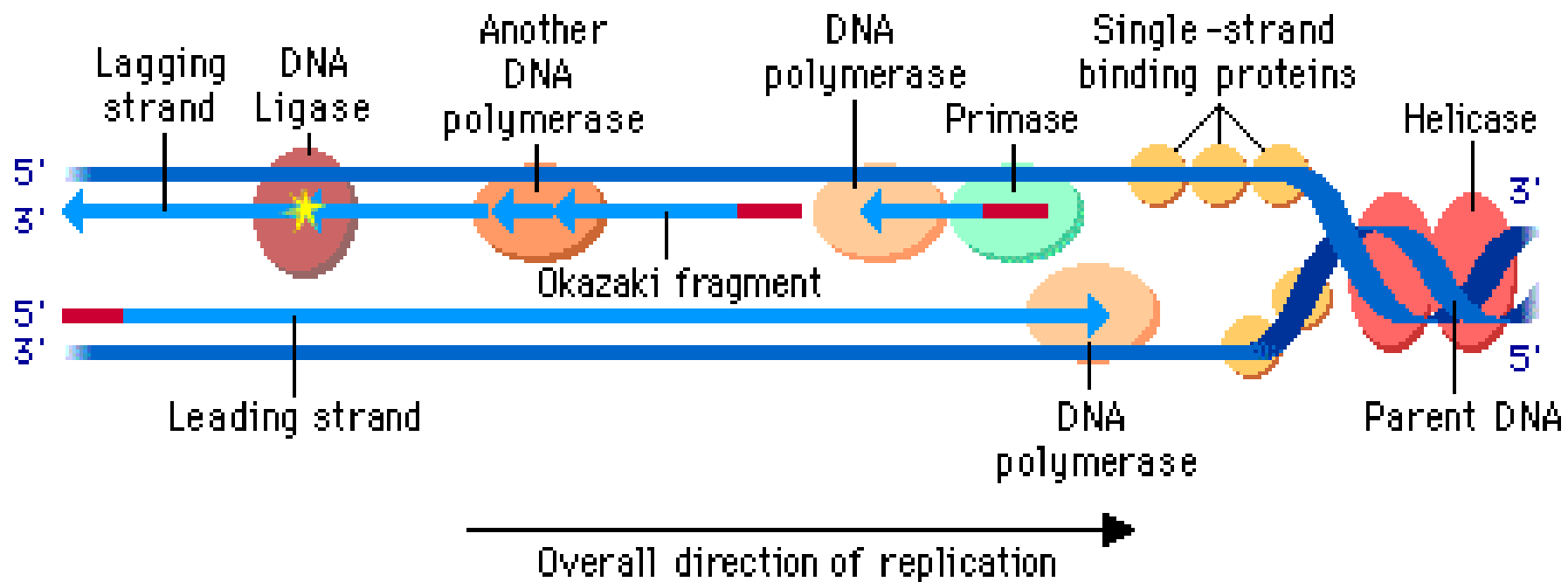

Termination (Telomeres)

- **Telomeres**
 - Short repeats of “G” base found at **END** of **LINEAR** chromosomes in **eukaryotes**
 - protect ends of linear chromosomes
 - The repeated sequence of GGGTTA make up the human telomeres.
- **Telomerase** is the enzyme that makes telomeres.

- Telomeres get shorter as cell divides → leads to aging???
- Most cancers come from body cells.
 - Cancers cell have ability to divide indefinitely.
 - Normal cells limited to ~50-75 divisions → stop making telomerase.
 - 85–90% cancer cells continue to make high levels of telomerase & are able to prevent further shortening of their telomeres.
 - Leads to “immortality”

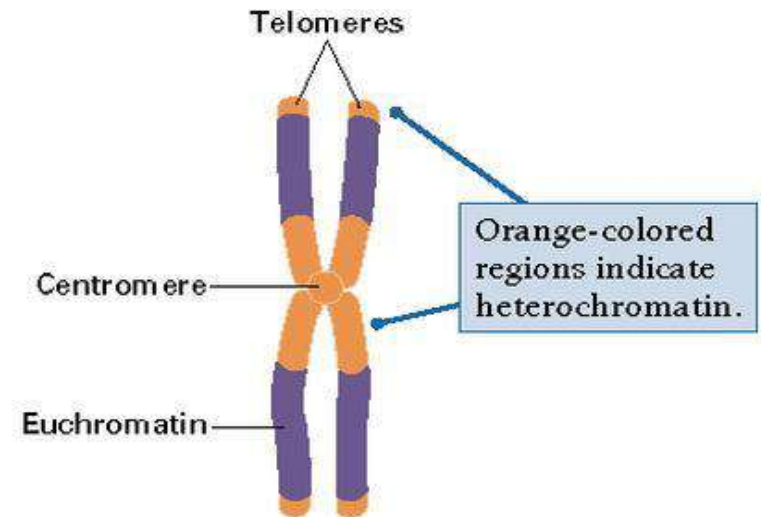

Probable Questions

1. **What kind of enzyme synthesizes the new DNA strand?**
2. **In what direction is the newly synthesized DNA produced?**
3. **The *E. coli* chromosome has 4.7×10^6 bp; a bi-directional replication fork progresses at about 1000 nucleotides/sec. What will be the minimum time required to complete replication ?**
4. **Why is an RNA primer necessary for DNA replication?**
5. **Describe the functions of topoisomerase.**
6. **Define Okazaki fragment. In which direction a newly synthesized lagging strand produced?**
7. **How do we know that DNA replication is Semi-conservative?**