

**VIVEKANANDA COLLEGE
THAKURPUKUR
KOLKATA-700063**

NAAC ACCREDITED 'A' GRADE



Topic: Interfacing Digital to Analog Converters

Course Title: Microprocessor and its Application

Paper: CMS-A-CC-4-10-TH

Unit: Interfacing Peripheral Devices and Applications

Semester: 4th Semester

Name of the Teacher: Amitava Biswas

Name of the Department: Computer Science

In many applications, the microprocessor has to produce analog signals for controlling certain analog devices. Basically the microprocessor system can produce only digital signals. In order to convert the digital signal to analog signal a Digital-to-Analog Converter. (DAC) has to be employed.

The DAC will accept a digital (binary) input and convert to analog voltage or current. Every DAC will have "n" input lines and an analog output.

The DAC require a reference analog voltage (V_{ref}) or current (I_{ref}) source.

The smallest possible analog value that can be represented by the n-bit binary code is called resolution. The resolution of DAC with n-bit binary input is $1/2^n$ of reference analog value. Every analog output will be a multiple of the resolution. In some converters the input reference analog signal will be multiplied or divided by a constant to get full scale value. Now the resolution will be $1/2^n$ of full scale value.

For example,

Consider an 8-bit DAC with reference analog voltage of 5 volts.

Now the resolution of the DAC is $(1/2^8) \times 5$ volts.

The 8-bit digital input can take, $2^8 = 256$ different values.

The analog values for all possible digital input are as shown in table below.

Digital Input	Analog Output
0000 0000	$\frac{0}{2^8} \times 5$ Volts
0000 0001	$\frac{1}{2^8} \times 5$ Volts
0000 0010	$\frac{2}{2^8} \times 5$ Volts
0000 0011	$\frac{3}{2^8} \times 5$ Volts
1111 1111	$\frac{255}{2^8} \times 5$ Volts

The maximum input digital signal will have an analog value which is equal to reference analog value minus resolution.

The digital-to-analog converters can be broadly classified into three categories, and they are

- Current output
- Voltage output
- Multiplying type

The current output DAC provides an analog current as output signal.

In voltage output DAC, the analog current signal is internally converted to voltage signal.

In multiplying type DAC, the output is given by the product of the input signal and the reference source and the product is linear over a broad range. Basically, there is not much difference between these three types and any DAC can be viewed as multiplying DAC.

Typical DAC circuit:

The basic components of a DAC are resistive network with appropriate values, switches, a reference source and a current to voltage converter as shown in figure below.

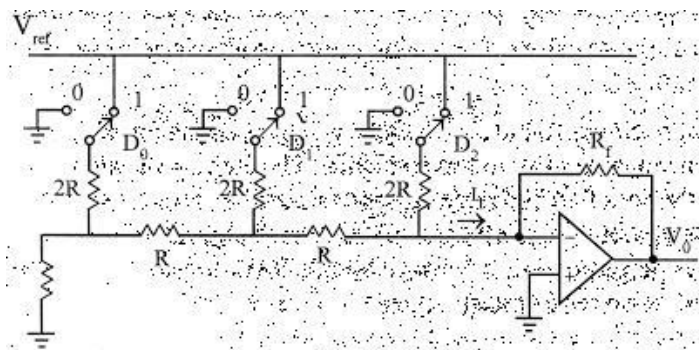

Fig 7.9 : A typical R / 2R ladder resistive network as DAC

The switches in the circuit of figure above can be transistors which connects the resistance either to ground or V_{ref} . The resistors are connected in such a way that for any number of inputs, the total current is in binary proportion. The operational amplifier converts the current to a voltage signal V_0 , which can be calculated from the following equation.

The circuit of figure shown above can be modified as 8-bit DAC, by increasing the number of R/2R ladder. For an 8-bit DAC the output voltage is given by

$$V_0 = V_{ref} \frac{R_f}{R} \left(\frac{D_2}{2^1} + \frac{D_1}{2^2} + \frac{D_0}{2^3} \right)$$

The time required for converting the digital signal to analog signal is called conversion time. It depends on the response time of the switching transistors and the output amplifier. If the DAC is interfaced to microprocessor then the digital data (Signal) should remain at the input of DAC, until the conversion is complete. Hence to hold the data a latch is provided at the input of DAC.

$$V_0 = V_{ref} \frac{R_f}{R} \left(\frac{D_7}{2^1} + \frac{D_6}{2^2} + \frac{D_5}{2^3} + \frac{D_4}{2^4} + \frac{D_3}{2^5} + \frac{D_2}{2^6} + \frac{D_1}{2^7} + \frac{D_0}{2^8} \right)$$

The Digital-to-Analog converters compatible to microprocessors are available with or without internal latch and I to V converting amplifier. The AD558 of Analog Devices is an example of 8-bit DAC with an internal latch and I to V converting amplifiers. The output of AD558 is an analog voltage signal. The AD558 can be directly interfaced to 8085 microprocessor bus and it requires only two control signals: Chip Select (CS) and Chip Enable (CE). [No handshake signals are necessary for interfacing a DAC. The time between loading two digital data to DAC is controlled by software time delay].

The DAC0808 of National Semiconductor Corporation is an example of 8-bit DAC without internal latch and I to V converting amplifier. The internal block diagram and the pin configuration of DAC0808 are shown in figure below.

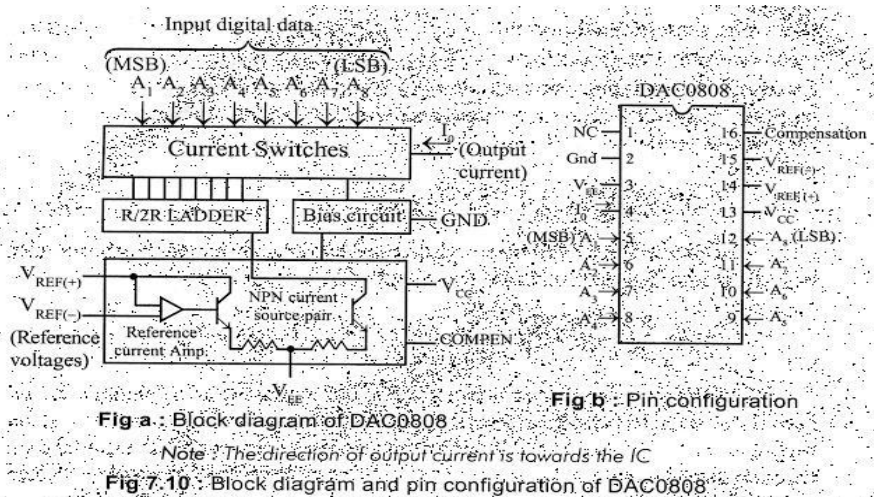

The DAC0800 can be interfaced to 8085 system through an 8-bit latch as shown in

figure below. The chip select (CS) signal from the decoder of the microprocessor system is delayed and inverted to clock the latch. If the DAC is memory mapped then the CS is from memory decoder. If the DAC is I/O mapped then CS is from I/O decoder.

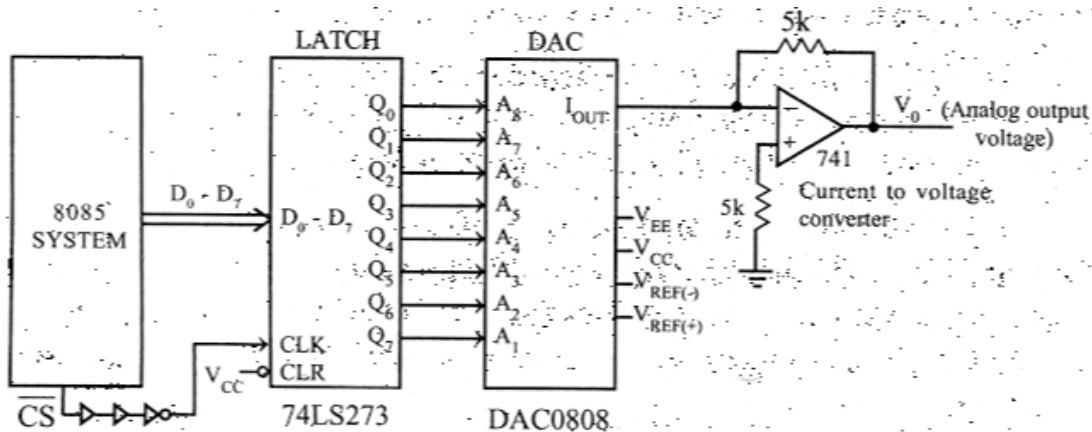

Fig 7.11 : Interfacing DAC0808 to 8085 microprocessor system

The processor sends an address, which is decoded by decoder in the microprocessor system to produce chip select signal. Then the processor sends a digital data to latch. The buffer and inverter will produce sufficient delay for CS signal so that, the latch is clocked only after the data is arrived at the input lines of the latch.

When the latch is clocked the digital data is send to DAC. The DAC will produce a corresponding current signal, which is converted to voltage signal by the op-amp 741. The typical settling time of DAC0800 is 150nsec. Therefore the processor need not wait for loading next data.