



STUDY MATERIAL

VIVEKANANDA COLLEGE THAKURPUKUR

NAAC ACCREDITED GRADE—'A'

**Course Name: Data Communication, Network and Internet
technology (CMSA)**

Topic: Switching and Telephone Network

**Subtopic: Circuit Switched Network, Packet Switched
Network, Virtual Circuit Switch**

Paper: CC8 (Theory)

Semester:4th

Name Of Teacher: Jhuma Mazumder

Department : Computer Science

Circuit-switched vs Packet-switched networks

Definitions

Circuit Switched Networks – Circuit switched networks are connection-oriented networks. Here, a dedicated route is established between the source and the destination and the entire message is transferred through it.

Packet Switched Networks – Packet switched networks are connectionless networks. Here, the message is divided and grouped into a number of units called packets that are individually routed from the source to the destination.

Comparisons

Differences with respect to technology

Serial Number	Circuit – Switching	Packet – Switching
1	It is a connection oriented network switching technique.	It is a connectionless network switching technique.
2	A dedicated path has to be established between the source and the destination before transfer of data commences. Once, the data is transmitted, the path is relinquished.	There is no need to establish a dedicated path from the source to the destination.
3	It is inflexible in nature since data packets are routed along the same dedicated path.	Each packet is routed separately. Consequently, it is flexible in nature where the different data packets follow different paths.
4	It was initially designed for voice transfer.	It was initially designed for data transfer.
5	The entire message is received in the order sent by the source.	The individual packets of the message are received out of order and so need to be reassembled at the destination.

6	It is implemented at Physical Layer.	It is implemented at Network Layer.
7	It has two approaches – <ul style="list-style-type: none"> • Space division switching, and • Time division switching 	It has two approaches – <ul style="list-style-type: none"> • Datagram, and • Virtual Circuit
8	It is not a store and forward transmission.	It is store and forward transmission.
9	Data is processed and transmitted at the source only.	Data is processed and transmitted, not only at the source but at each switching station.

Differences with respect to applicability, advantages and disadvantages.

Serial Number	Circuit – Switching Networks	Packet – Switching Networks
1	They are suitable for long continuous transmission, like voice calls.	They are unsuitable for applications that cannot afford delays in communication like high quality voice calls.
2	Once a route is established between the source and the destination, the route cannot be used by any other user. This leads to poor utilization of resources.	It allows simultaneous usage of the same channel by multiple users. This guarantees better resource utilization.
3	Bandwidth requirement is high even in cases of low data volume.	It ensures better bandwidth usage as a number of packets from multiple sources can be transferred via the same

		link.
4	Time required to establish connection may be high.	Delay in delivery of packets is less, since packets are sent as soon as they are available.
5	Initial cost is low.	Packet switching high installation costs.
6	The protocols for delivery are relatively simpler.	They require complex protocols for delivery.
7	It is more reliable.	It is less reliable.

Diagrammatic Representations

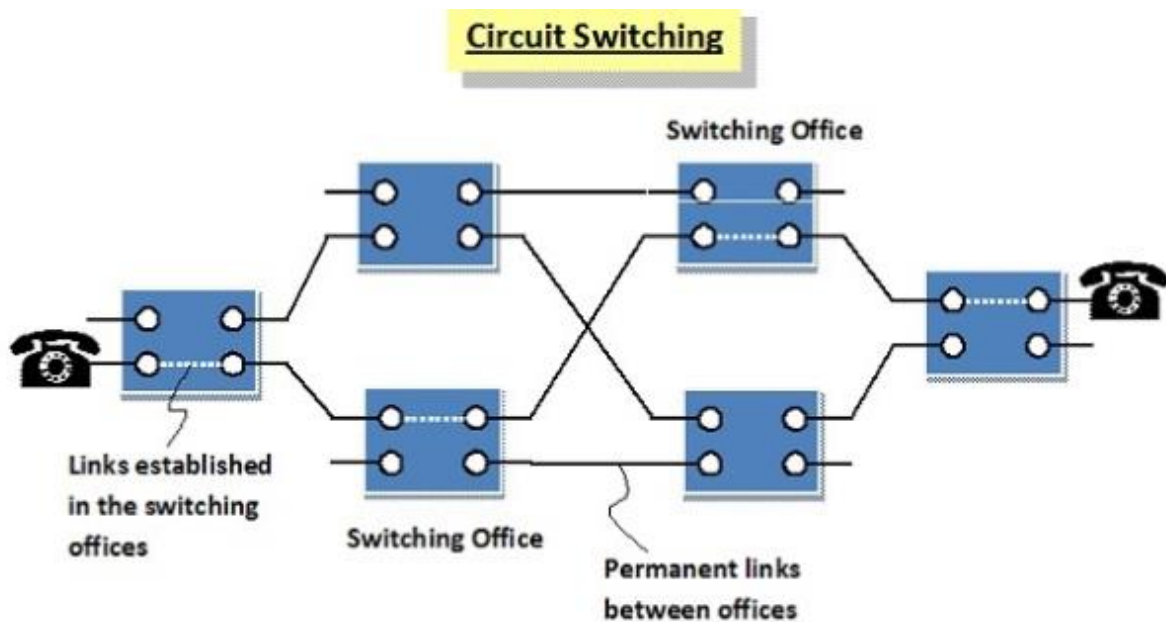

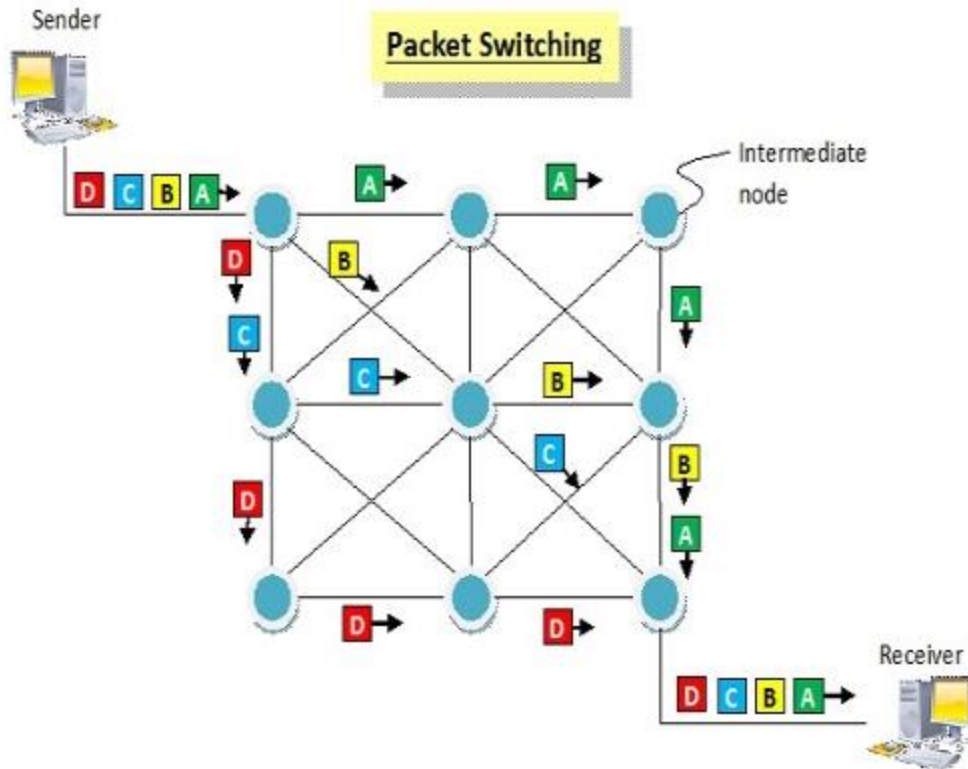

Virtual circuit switching

Virtual circuit switching is a packet switching methodology whereby a path is established between the source and the final destination through which all the packets will be routed during a call. This path is called a virtual circuit because to the user, the connection appears to be a dedicated physical circuit. However, other communications may also be sharing the parts of the same path.

Before the data transfer begins, the source and destination identify a suitable path for the virtual circuit. All intermediate nodes between the two points put an entry of the routing in their routing table for the call. Additional parameters, such as the maximum packet size, are also exchanged between the source and the destination during call setup. The virtual circuit is cleared after the data transfer is completed.

Virtual circuit packet switching is connection orientated. This is in contrast to datagram switching, which is a connection less packet switching methodology.

Advantages of virtual circuit switching are:

- Packets are delivered in order,
since they all take the same route;
- The overhead in the packets is smaller,
since there is no need for each packet to contain the full address;
- The connection is more reliable,
network resources are allocated at call setup so that even during times of congestion,
provided that a call has been setup, the subsequent packets should get through;
- Billing is easier,
since billing records need only be generated per call and not per packet.

Disadvantages of a virtual circuit switched network are:

- The switching equipment needs to be more powerful,
since each switch needs to store details of all the calls that are passing through it and to
allocate capacity for any traffic that each call could generate;
- Resilience to the loss of a trunk is more difficult,
since if there is a failure all the calls must be dynamically reestablished over a different
route.

Examples of virtual circuit switching are X.25 and Frame Relay.