

VIVEKANANDA COLLEGE  
THAKURPUKUR  
KOLKATA-700063  
NAAC ACCREDITED 'A' GRADE



Topic: *Agaricus bisporus* Cultivation Technology

Course Title: Mushroom Culture Technology

Paper: BOT-A-SEC-B-4-4

Unit: 2

Semester: IV

Name of the Teacher: Dr Asis Kumar Pal

Name of the Department: Botany

## Cultivation of White button mushroom (*Agaricus brunnescens*= *A. bisporus*)

*Agaricus brunnescens* (*A. bisporus*) commonly called **white button mushroom** is characterized by 2-spored basidia. The fungus body is usually more robust and the flesh is thicker and firmer than the wild field mushroom, *A. campestris* that grows amongst grass in pastures, on old lawns, etc. often growing as 'fairy rings'.

### The protocol for cultivation of *A. bisporus* requires the following steps:

1. Spawn preparation.
2. Preparation of compost
3. Filling of tray beds with compost
4. Spawning (inoculation) of beds
5. Casing
6. Watering of beds
7. Harvesting of mushrooms
8. Storage

### Requirements

- Mushroom house (any suitable 'kucha' or 'pucca' house)
- Cement concrete platform (14 x 7 meters) for preparing compost
- Tray beds (wooden trays made of *Pinus* and Deodar wood, 100 x 50 x 22 cm)
- Compost ingredients
- Spawn (mushroom seed) of *A. bisporus* (can be obtained from NCMRT, Solan, H.P. or other such agencies)– 10 bottles/25 beds
- Casing soil
- Sprayer with a fine nozzle
- Box for gathering mushrooms
- Sterilization facility
- Wooden mould (it consists of three wooden boards: one end board and two side boards, fastened with a clamp with notches at the top)
- Wooden broad (25 x 12 cm) with handle for compressing the compost
- Newspaper sheets
- Lime or carbonate of lime
- pH meter

### Procedure

#### 1. Preparation of Compost

Compost is the substrate of which mushroom grows. The biochemical activity of a number of microorganisms make the substrate selective for the growth of *A. bisporus*. The process of compost making is called **composting**. It is defined as indefinite microbial degradation of organic wastes. During composting, distinct changes occur in the physical, chemical and biological characteristics of the straw, all of which influence the productivity of *A. bisporus* subsequently. A synthetic compost, made out of wheat straw for growing *A. bisporus* consists of the following constituents (for 25 tray beds):

Chopped wheat straw (3-6 cm long)	300.0 kg
Wheat bran	15.0 kg
Calcium ammonium nitrate (or Ammonium sulfate)	6.0 kg
Superphosphate	7.5 kg
Urea	2.4 kg
Potassium sulfate	3.0 kg
Gypsum	30.0 kg
Saw dust	10-12 kg

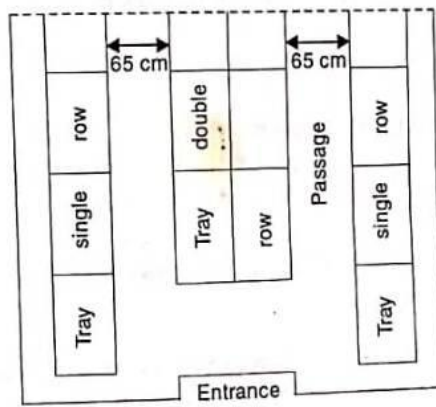
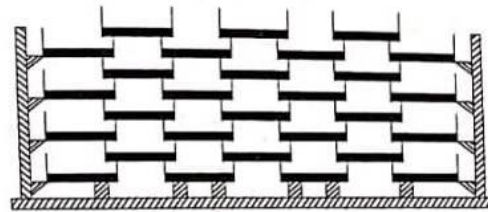
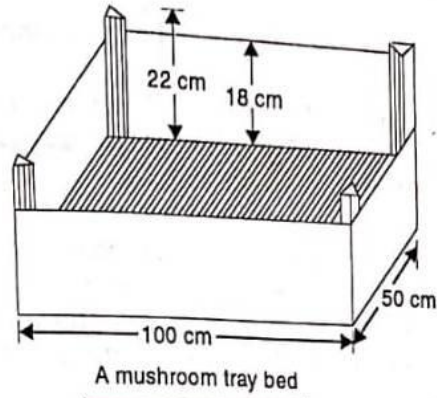

### Details of mushroom tray bed and mode of stacking of trays for cropping of white button mushroom

## Procedure

1. Wet the saw dust by spraying water or leaving it overnight after mixing all the constituents except wheat straw.
2. Spread the wheat straw over the cement floor on the following day and wet it thoroughly by sprinkling water.
3. Spread the pre-mixed constituents over the wheat straw surface and mix thoroughly.
4. Stack this mixture into a pile of 1.30 meters wide and 1.30 meters high, using indigenously fabricated wooden-mould
5. Allow the compost to decompose for 28-30 days under aerobic conditions in the compost pile.
6. Dismantle the heap (pile) repeatedly and prepare pile again and again at periodic intervals by placing the outer compost inside and inner compost layers in the outer periphery, the process called **turning of the compost pile**, to obtain uniform fermentation of the entire pile. Watering is to be done in the first two turnings.

For good results, periodic turning of the pile should be done according to the following schedule:

**First turning:** 6th day, add more fertilizers (CAN or ammonium sulfate, 3 kg and urea, 1.2 kg) and wheat bran (15 kg).

**Second turning:** 10th day, add gypsum (30 kg) and more water.

**Third to seventh turning:** After every 3 days, 25th day should normally be the last day for turning the compost.

## Observations

Well prepared compost will be brown to dark brown in colour and free from ammonia in colour.

### 2. Filling of Tray beds

- (a) Spread the prepared compost on the platform.
- (b) Mix 3 kg of calcium carbonate to it.
- (c) Fill the compost in all corners and edges of a tray.
- (d) Compress fairly the compost in the tray using a wooden board leaving 1 cm clear space on the top of the tray.

### 3. Spawning

Spawning means planting mushroom mycelium, growing on a suitable substrate, in the compost. *A. bisporus* spawn is especially grown on wheat or sorghum grains in specialized spawn laboratories. It is prepared and sold in India by several Government and non-Government agencies. One such central Government Institute is the **National Centre for Mushroom Research and Training (NCMRT), Chambaghat, Solan-173 213 (HP), India.**

- (a) Perform the spawning by spreading the spawn on tray beds when half filled with compost and again after the tray is filled completely. During spawning, the spawn is gently mixed with fore-fingers and pressed uniformly each time.

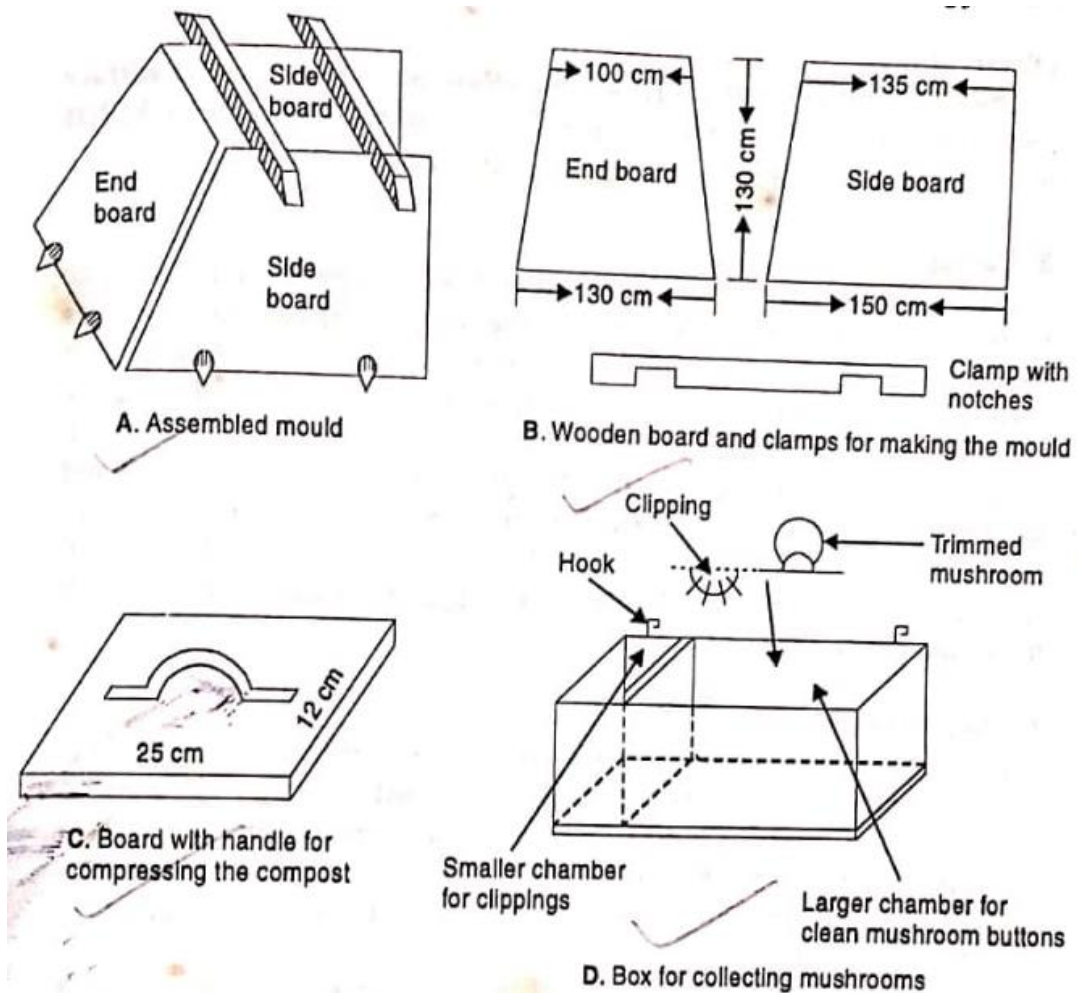

Appliances used in mushroom cultivation: **(A)** Assembled mould, fabricated from wooden board and clamps of the size and shape as illustrated in the figure; **(B)** used for making compost pile from the mixed ingredients; **(c)** Wooden board (25 x 12 cm) used for compressing the compost in the trays; **(D)** Box for collecting mushrooms. It has two chambers of unequal sizes, larger for collecting mushroom buttons, the bottom of which opens up for emptying the box, and the smaller for collecting clippings. The box is also fitted with two hooks for resting it against the side board of mushroom tray during harvesting.

- (b) Cover the trays with newspaper sheets
  - (c) Sprinkle water on newspaper sheets, to provide humidity.
  - (d) Stack the inoculated trays vertically, one over the other, depending on the height of the room.
  - (e) Continue water spraying twice a day or less depending upon available humidity in the atmosphere throughout the spawn running and cropping period.
4. Maintain temperature of the room between 24°C and 25°C for 12-15 days for running of the spawn i.e. formation of mycelium strands all over the tray beds.

### **Observations**

Observe for the **white cottony mycelium** over the compost surface and colour of the compost that changes from dark to light brown which is indicative of successful completion of spawn running period.

### **5. Casing**

Casing means covering the compost with a thin layer of soil or soil like material after the spawn has spread in the compost (**spawn run**). Soil has been the universal casing material. But all soils as such cannot be used as 'casing soil' with advantage, so it is especially prepared soil that can be used for casing. In India, a number of mixtures have been recommended: (a) well rotten cow dung, mixed with light soil in 3:1 ratio; (b) soil and sand in the ratio of 1:1; (c) farm yard manure and gravel, ratio 4:1; (d) farm yard manure and loam ration 1:1; (e) soil peat mixture 2:1; and (f) spent compost, sand and slaked lime (4:1:1) and nematicide mixture. Of these, the 6th one is most oftenly used.

#### **A. Preparation of Casing Soil**

- (a) Mix four parts of spent compost with one part of sand of which 5 kg of slaked lime per cubic metre of compost is added.
- (b) Treat the mixture with nemagon, a nematicide, by spraying or sprinkling it at the rate of 5 ml per cbm.
- (c) Leave the material in a pile (1.20 M x 1.0 M) under a tree shade for a period of one year, turning it every 4 months.
- (d) Sieve the spent compost, which turns into black soil in one year, for removal of undecomposed lumps.

### **Observations**

Observe the casing soil for black colour and pH. A pH between 8.0 and 8.5 is the most suitable for mushroom yield.

Adjust pH, if desired, by the addition of lime or carbonate of lime or free stone to the casing mixture.

#### **B. Sterilization of Casing soil**

Sterilize the casing material either by the chemicals (formalin, chloropicrin, methyl bromide or vapam) or by heating or by steam from boiler through perforated pipes and temperature raised to 70°C-75°C and maintained for 6 hours. The purpose of sterilization is to kill harmful microorganism (fungi, nematodes, insects).

#### **C. Casing the Beds**

- (a) Remove the newspaper sheets from the spawned beds after 3 weeks.
- (b) Gently press the compost with the help of wooden board.
- (c) Cover the beds with 2.0-2.5 cm thick layer of sterilized casing material.

### **6. Watering of Beds**

Spray the beds over the casing soil with a fine nozzle of a sprayer to maintain relative humidity between 70 and 80 per cent.

## Observations

Observe the beds for mushroom crop which can be expected after 5 to 20 days. Mushrooms mostly appear in 'flushes' and at a temperature of 15°C, it generally takes 7 to 8 days to come to the button stage from the first appearance of the formation of a pin-head. There is an interval of 8 to 10 days between flushes.

## 7. Harvesting of Mushrooms

Harvest the crop everyday (in the morning and evening depending upon the market demand) to get a good quality of mushrooms (**the cap still being tight to its stalk is the right stage to harvest the mushrooms**).

Harvesting is done by holding the cap with fore-fingers slightly pressed against the soil and twisted out. The mycelial strands and soil particles clinging to the base of the stalk (stem) are cut off with a knife. Specially designed wooden box is used for collection of mushrooms from multistoried trays, each provided with the hooks for resting it against the side board of the mushroom tray.

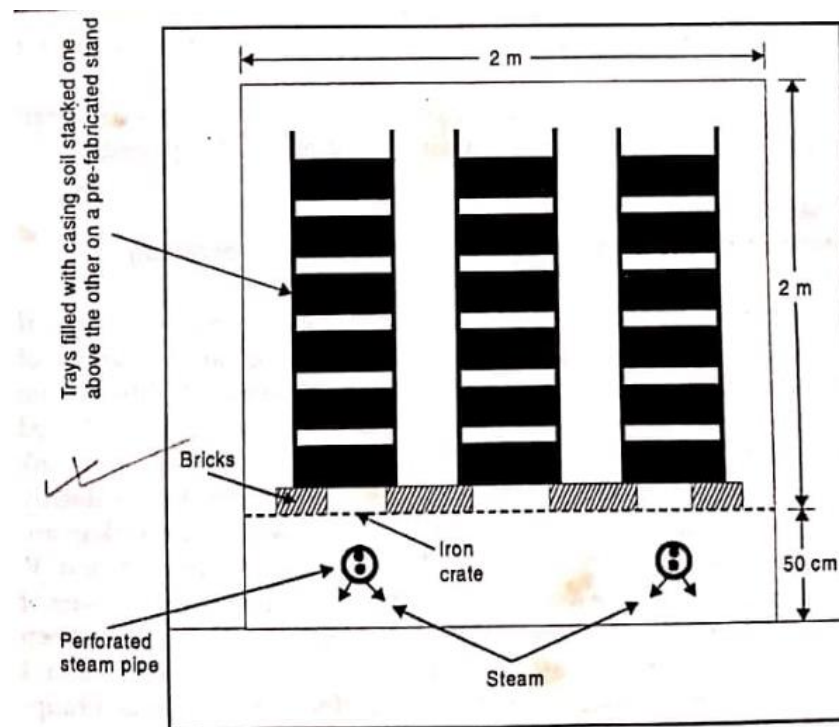

Outline plan of a specially equipped room for pasturization (sterilization) of casing soil. The temperature of the soil is maintained at 70°C-75°C for 6 hours to obtain effective sterilization

## 8. Storage

Store the mushrooms at 4°C in a refrigerator for a few days to avoid the quality deterioration, because mushrooms are a highly perishable commodity. The white colour turns

brown and then black in a couple of hours at high summer temperature. Soon after water oozes out and the mushrooms become unfit for cooking.

### **Precautions**

1. Always prepare compost with white-straw over 300 kg in quantity, as the heat generated in smaller piles will not be sufficient for fermentation.
2. The compost pile should not become hard pressed to avoid anaerobic conditions as decomposition takes place only under aerobic conditions.
3. If ammonia smell is noticeable, more turning of the compost should be done to free the compost from ammonia smell.
4. Care should be taken to wet the composting material to the extent that water drops do not ooze out, if the compost is squeezed in the palm of hand.
5. Water should never be poured over the spawn to avoid the failure of the crop.
6. Proper care should be taken not to allow the temperature to rise above 75°C so that useful microorganisms present in the soil are not killed.
7. Care should be taken to leave at least one metre clear space in between the last tray and the ceiling, so that air circulation is not impaired.

### **FURTHER READINGS**

- . Tewari, Pankaj Kapoor, S.C., (1988). Mushroom cultivation, Mittal Publications, Delhi.
- . Nita Bahl (1984-1988) Hand book of Mushrooms, II Edition, Vol. I & Vol. II.